



RECOIL[®]

SL1779

Underseat Active Slim 7" X 9" Subwoofer
with Passive Radiators

User Manual

Introduction

Please read this OWNER'S MANUAL thoroughly to familiarize yourself with each control and function. We hope that your new underseat active subwoofer SL1779 will give you many years of listening enjoyment. In case of problems when installing your subwoofer, please contact support@recoilaudio.com.



This symbol means important instructions.

WARNING

Failure to heed them can result in serious injury or death.



This symbol means important instructions.

CAUTION

Failure to heed them can result in injury or property damages.

WARNING

- **DO NOT OPERATE ANY FUNCTION THAT TAKES YOUR ATTENTION AWAY FROM SAFELY DRIVING YOUR VEHICLE.** Any function that requires your prolonged attention should only be performed after coming to a complete stop. Always stop the vehicle in a safe location before performing these functions. Failure to do so may result in an accident.
- **KEEP THE VOLUME AT A LEVEL WHERE YOU CAN STILL HEAR OUTSIDE NOISES WHILE DRIVING.** Excessive volume levels that obscure sounds such as emergency vehicle sirens or road warning signals (train crossings, etc.) can be dangerous and may result in an accident. LISTENING AT LOUD VOLUME LEVELS IN A CAR MAY ALSO CAUSE HEARING DAMAGE.
- **DO NOT DISASSEMBLE.** Doing so may result in an accident, fire or electric shock.
- **USE THIS PRODUCT FOR MOBILE 12V APPLICATIONS.** Use for other than its designed application may result in fire, electric shock or other injury.
- **USE THE CORRECT AMPERE RATING WHEN REPLACING FUSES.** Failure to do so may result in fire or electric shock.
- **DO NOT BLOCK VENTS OR RADIATOR PANELS.** Doing so may cause heat to build up inside and may result in fire.
- **MAKE THE CORRECT CONNECTIONS.** Failure to make the proper connections may result in fire or product damage.
- **USE ONLY IN VEHICLES WITH A 12 VOLT NEGATIVE GROUND.** Failure to do SO may result in fire, etc.

- **BEFORE WIRING, DISCONNECT THE CABLE FROM THE NEGATIVE BATTERY TERMINAL.** Failure to do so may result in electric shock or injury due to electrical shorts.
- **DO NOT ALLOW CABLES TO BECOME ENTANGLED IN SURROUNDING OBJECTS.** Arrange wiring and cables in compliance with the manual to prevent obstructions when driving. Cables or wiring that obstruct or hang up on places such as the steering wheel, gear lever, brake pedals, etc. can be extremely hazardous.
- **DO NOT SPLICE INTO ELECTRICAL CABLES.** Never cut away cable insulation to supply power to other equipment. Doing so will exceed the current carrying capacity of the wire and result in fire or electric shock.
- **DO NOT DAMAGE PIPE OR WIRING WHEN DRILLING HOLES.** When drilling holes in the chassis for installation, take precautions so as not to contact, damage or obstruct pipes, fuel lines, tanks or electrical wiring. Failure to take such precautions may result in fire.
- **DO NOT USE BOLTS OR NUTS IN THE BRAKE OR STEERING SYSTEMS TO MAKE GROUND CONNECTIONS.** Bolts or nuts used for the brake or steering systems (or any other safety-related system), or tanks should NEVER be used for installations or ground connections. Using such parts could disable control of the vehicle and cause fire etc.
- **KEEP SMALL OBJECTS SUCH AS BOLTS OR SCREWS OUT OF THE REACH OF CHILDREN.** Swallowing them may result in serious injury. If swallowed, consult a physician immediately.

CAUTION

- **HALT USE IMMEDIATELY IF A PROBLEM APPEARS.** Failure to do so may cause personal injury or damage to the product. Return it to our Service Center for repairing.
- **HAVE THE WIRING AND INSTALLATION DONE BY EXPERTS.** The wiring and installation of this unit requires special technical skill and experience. To ensure safety, always contact the dealer where you purchased this product to have the work done.
- **USE SPECIFIED ACCESSORY PARTS AND INSTALL THEM SECURELY.** Be sure to use only the specified accessory parts. Use of other than designated parts may damage this unit internally or may not securely install the unit in place. This may cause parts to become loose resulting in hazards or product failure.
- **ARRANGE THE WIRING SO IT IS NOT CRIMPED OR PINCHED BY A SHARP METAL EDGE.** Route the cables and wiring away from moving parts (like the seat rails) or sharp or pointed edges. This will prevent crimping and damage to the wiring. If wiring passes through a hole in metal, use a rubber grommet to prevent the wire's insulation from being cut by the metal edge of the hole.

• **DO NOT INSTALL IN LOCATIONS WITH HIGH MOISTURE OR DUST.** Avoid installing the unit in locations with high incidence of moisture or dust. Moisture or dust that penetrates into this unit may result in product failure.

SERVICE CARE

• IMPORTANT NOTICE

This Subwoofer has been tested to comply with the limits for a Class B computing device in accordance with the specifications of Part 15 of FCC Rules. This equipment generates and uses radio frequency energy, and it must be installed and used properly in accordance with the manufacturer's instructions.

• For Customers in other Countries IMPORTANT NOTICE

Customers who purchase the product with which this notice is packaged, and who make this purchase in other countries , please contact your dealer for information regarding warranty coverage.

SERIAL NUMBER:

INSTALLATION DATE:

INSTALLATION TECHNICIAN:

PLACE OF PURCHASE:

• IMPORTANT

Please record the serial number of your unit in the space provided here and keep it as a permanent record. The serial number plate is located on the rear of the unit.

SPECIFICATIONS

Sound	
Power Output (RMS)	230 watts
Frequency Response	34~ 400Hz
Woofers	
Diaphragm Size (Nominal)	7" X 9"
Passive Radiators	4" X 6"
Diaphragm Material	Polypropylene
Surround	Rubber
Amplifier	
Power Output (RMS)	230 watts
Low Pass Crossover	30~150Hz
Input Sensitivity	0.1-5.0V (RCA Input) 0.5-10.0V (Speaker Level Input)
Accessories	
Bass Remote Knob	Cable length: 5M
Wire Harness	OFC 17' Power/2' Ground/8' Spaker Level Input/2' Remote Turn on

ACCESSORIES

- Fuse(30A) 1
- Insert power cable 1
- Remote control 1
- Bracket 4
- Screws 8
- Brackets screws..... 8

NOTE :

• For product improvement, specifications and design are subject to change without notice.

INSTALLATION (Fig.1) & (Fig.2)

 **CAUTION**

• **Caution on connection terminals/parts**

Keep electrically conductive objects away from the unit's terminals/parts (power terminals, fuses, speaker input terminals, RCA connectors, etc.). Doing so prevents a possible short circuit and damage to the unit.

MOUNTING

1. Attach the included mounting brackets to the SL1779 with the supplied screws. (See to Fig. 1)
2. Once the brackets are mounted to the SL1779. Place the subwoofer in the desired location within the vehicle. Before securing with screws, check to make sure all screws can affix to a structurally solid surface while avoiding vehicle wiring, components, etc. (See Fig. 2)

Note: For securing the mounting brackets to the vehicle, it may be necessary to use longer screws (not included) to accommodate carpet thickness, etc.

NOTE:

To securely connect the ground lead, use an already installed screw on the metal part of the vehicle (marked this is a good ground by checking continuity to the battery (-) terminal. As much as possible connect all equipment same ground point. These procedures will help eliminate noise.

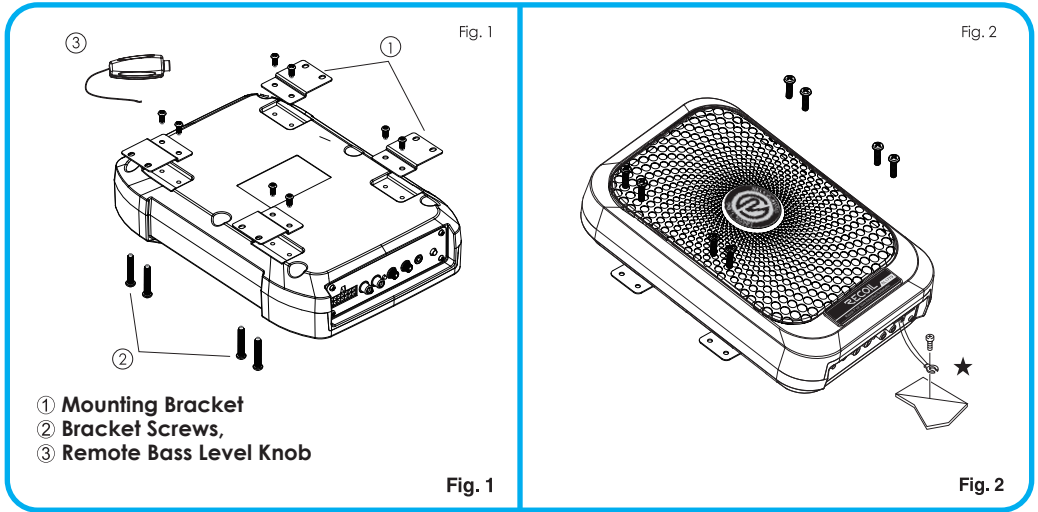

CONNECTIONS (Fig.3)

Before making connections, be sure to turn the power off to all audio components. Connect the red battery lead from the amp directly to the positive (+) terminal of the vehicle's battery. Do not connect this lead to the fuse block.

To prevent external noise from entering the audio system.

- Locate the unit and route the leads at least 10 cm (3- 15/16") away from the car harness.
- Keep the battery power leads as far away from other leads as possible.
- Connect the ground lead securely to a bare metal spot (remove any paint or grease if necessary) of the car chassis.
- Your dealer knows best about noise prevention measures so consult your dealer for further information.

1. Input/Power Connector

2. RCA Input Jacks

Connect these jacks to the line out leads on your headunit using RCA extension cables (sold separately).

Fig.3

RCA Input System

F Head Unit, etc (sold separately)

G RCA Extension Cable (sold separately)

Note:
Power Mode
button must
be set to REM
(Button Out)

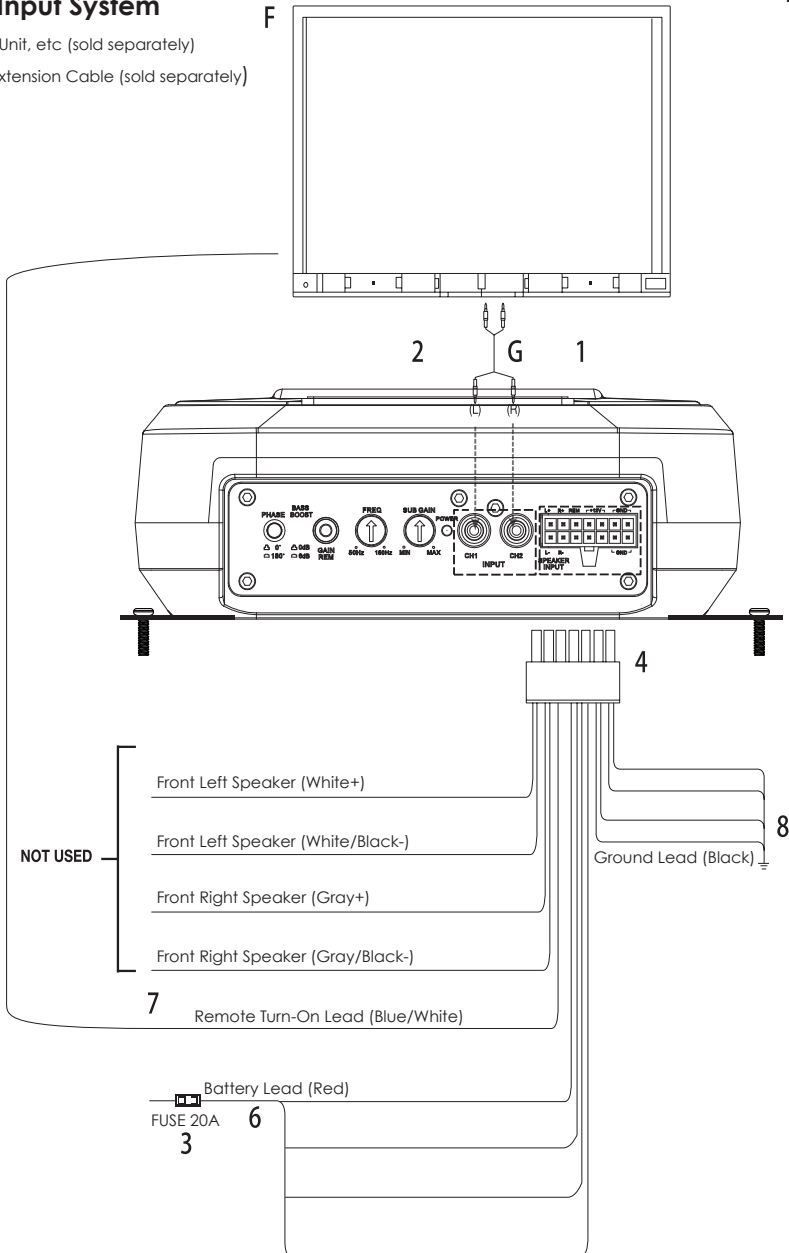

3. Fuse (30A)

USE ONLY THE CORRECT AMPERE RATING WHEN REPLACING FUSES. Failure to do so may result in fire or electric shock.

4. Input/Power Wire Harness

5. Speaker Input Leads

These leads are input leads for use with head units not equipped with preamp outputs. When not using the RCA Line Input connectors, you should connect these wires to the speaker output leads of your head unit. The accepts input from high power or standard power head units.

Note:

- Do not connect speaker leads together or to chassis ground.
- Use either RCA line level or speaker level inputs. Do not connect both at the same time.

6. Battery Lead (Red)

Connect battery lead directly to BATT + Be sure to add a 30A fuse as close as possible to the battery's (+) terminal.

7. Remote Turn-On Lead (Blue/White)

Connect this lead to the remote turn-on (positive trigger, (+) 12V only) lead of your head unit.

Note:

If using speaker input level signal from the head unit, remote turn-on lead connection is not necessary.

8. Ground Lead (Black)

Connect this lead securely to a clean, bare metal spot on the vehicle's chassis. Verify this point to be a true ground by checking for continuity between that point and the negative (-) terminal of the vehicle's battery. Ground all your audio components to the same point on the chassis to prevent ground loops.

Speaker level input system

Fig.3

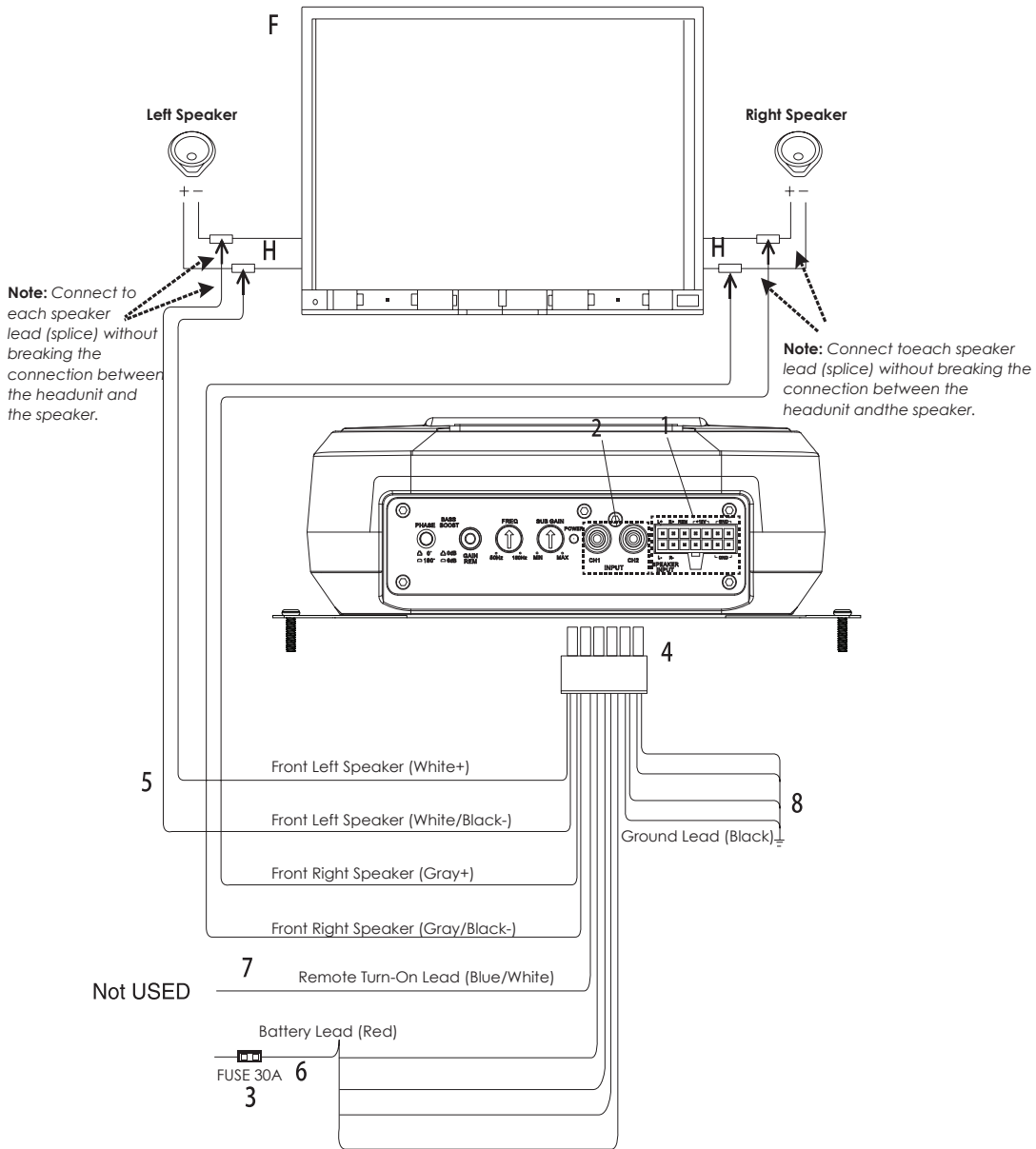

SWITCH SETTINGS (Fig. 4)

9. Phase switch 0° to 180°

Subwoofer output phase can be set to Subwoofer Normal 0° (Button Out) or Subwoofer Reverse 180° (Button In).

10. Crossover Frequency Adjustment Knob (LP FILTER)

Use this control to adjust the crossover frequency between 50 to 150Hz.

11. Input Gain Adjustment Control

Note: If the Remote Bass Level Knob will be connected in your system, make sure to rotate the knob fully clockwise (set to "+") before making the input gain adjustment.

Set the SL1779 input gain to the minimum position. Using a dynamic CD as a source, increase the head unit volume until the output distorts. Then, reduce the volume 1 step (or until the output is no longer distorted). Now, increase the amplifier gain until the sound from the speakers becomes distorted. Reduce the gain slightly so the sound is no longer distorted to achieve the optimum gain setting.

12. Power Indicator

Indication Color	Status	Solution
Blue	Amplifier circuit is normal	
None (LED is off)	Amplifier circuit is abnormal. An electrical short has occurred, or supply current is too high. 30A fuse may be blown.	Turn off the power supply and eliminate the cause (replacethe 30A if necessary) Then turn on the unit and verify that the LED has turned on. If it remains off, turn off the unit and consult your dealer.
	Power supply voltage is too high.	Use the correct power supply voltage.

13. Remote Adjustment Knob

Turning the remote bass level knob towards (+) increases the overall subwoofer level, while turning the bass level knob towards (-) decreases the overall subwoofer level.

(Note: can be used without connecting the remote bass level knob. However, overall subwoofer level cannot be adjusted from the listening position.)

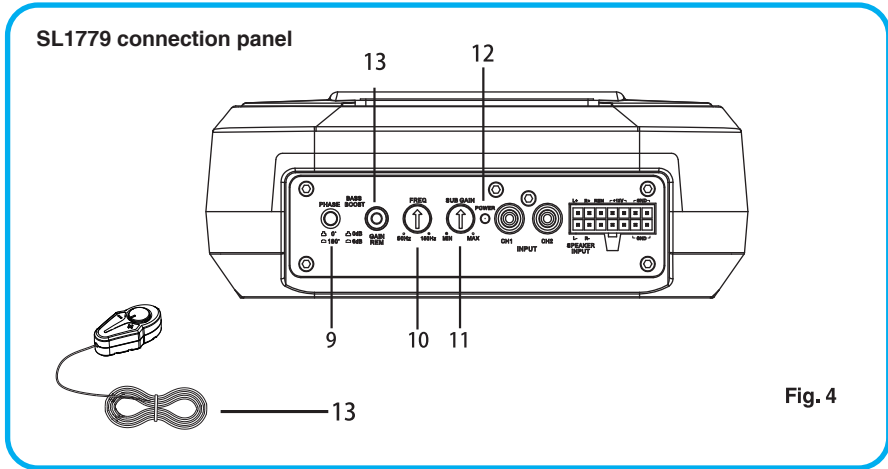

Fig. 4

CONNECTION CHECKLIST (Fig. 5)

Please check your head unit for the conditions listed below: (Fig. 4)

- a. The head unit does not have a remote turn-on or power antenna lead.
- b. The head unit's power antenna lead is activated only when the radio is on (turns off in the tape or CD Mode).
- c. The head unit's power antenna lead is logic level output (+) 5V, negative trigger (grounding type), or cannot sustain (+) 12V when connected to other equipment in addition to the vehicle's power antenna. If any of the above conditions exist, the remote turn-on lead of your must be connected to a switched power source (ignition) in the vehicle. Be sure to use a 3A fuse as close as possible to this ignition tap. Using this connection method, the Q9 will turn on and stay on as long as the ignition switch is on.

If this is objectionable, a SPST (Single Pole, Single Throw) switch, in addition to the 3A fuse mentioned above, may be installed in-line on the turn-on lead. This switch will then be used to turn on (and off) the . Therefore, the switch should be mounted so that is accessible by the driver.

Make sure the switch is turned off when the vehicle is not running, Otherwise, the subwoofer will remain on and drain the battery.

- ① Blue/White
- ② Power Antenna
- ③ Remote Turn-On Lead
- ④ To other components' Remote Turn-On L leads
- ⑤ SPST Switch (optional)
- ⑥ Fuse (3A)
- ⑦ As close as possible to the vehicle's ignition tap
- ⑧ Ignition Source

Connection panel

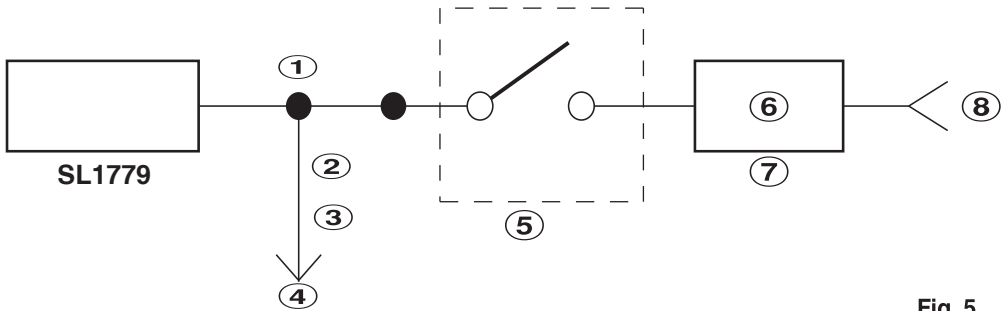

Fig. 5

Dimensions

