



RECOIL[®]

AMP500.4

Powersports 4-Channel Class-D Full-Range Amplifier

User Manual

Owner' S manual- AMP500.4

The AMP500.4 amplifier is a state of the art Class D amplifier designed to provide great amplification in a small space for your marine or off-road audio system. The AMP500.4 is a 4-channel full range amplifier with fully variable high pass and low pass crossovers enabling it to drive a wide variety of either full range speakers or subwoofers.

The AMP500.4 amplifier is meant to work with the Recoil RB1 Bluetooth® controller. However a RCA adapter is included in case you wish to use a different head unit. For more details contact us at support@recoilaudio.com.

What's Included

- AMP500.4 - 4 channels Marine amplifier
- 8' power wire
- 40A fuse and fuse holder
- 4 pcs of mounting screws
- 1pc DIN or RCA Adapter

WIRE#	COLOR CODE	FUNCTIONE
1	Red	+12V
2	Black	Ground
3	Blue	Remote
4	Green	Rear Left+ /Bridged+
5	Green/Black	Rear Left-
6	Purple/Black	Rear Right -/Bridged-
7	Purple/Black	Rear Right +
8	White	Front Left+ /Bridged+
9	White/Black	Front Left-
10	Grey/Black	Front Right -/Bridged-
11	Grey	Front Right +

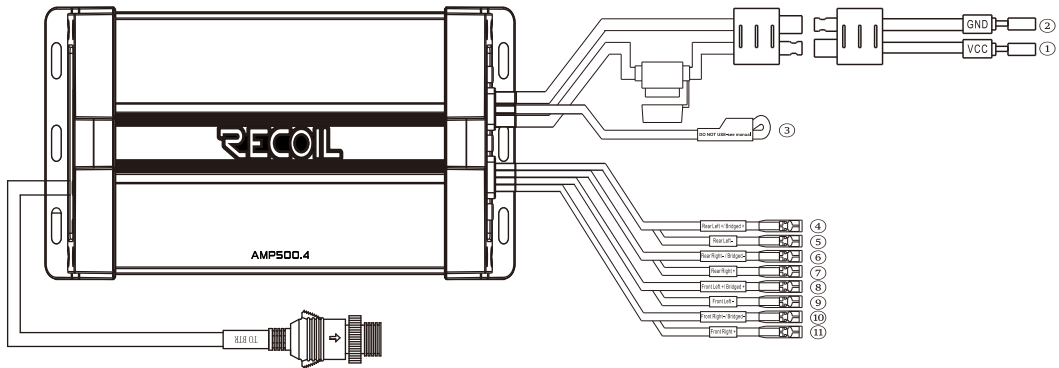

1. Input - waterproof DIN plug allows you to connect your AMP500.4 amplifier to the Recoil RB1 Bluetooth® controller/receiver or to our RCA adapter - MMD-FRCA.
2. Red / positive power wire - includes a 40A fuse and fuse holder.
3. Black / ground power wire.
4. Blue / remote Turn On - if you use the Recoil RB1 controller as the head unit, DO NOT use this Blue wire. In case you use a different source/ head unit, you'll need to use our RCA adapter, model MMD- FRCA
5. Output channels.

IMPORATNT! (Dear customer, read this before you install)

1. WATER DAMAGES TO YOUR AMP500.4 AMPLIFIER, ARE NOT COVERED BY THE PRODUCTS WARRANTY:

Our engineering team designed the AMP500.4's chassis to be Marine rated, but you must install it where it's protected from water/mud at **all times**. The sealed structure is designed and constructed to protect the amplifier **IN CASE** it accidentally gets wet, but it is your responsibility to limit the amp's exposure to water:

- Install the amplifier in a dry area where water and mud can't reach it.
- Do not clean the amplifier with high pressure or regular water hose. If needed, cover it while washing your vehicle.

2. DO NOT use the Blue remote-in wires on your amplifier if you use the Recoil RB1 as your head unit:

Your AMP500.4 amplifier connects to the RB1 controller with our unique mini DIN plug. This Plug already includes a remote trigger feature in it. Thus, you should not use the Blue remote-in wire.

In case you use a different head unit / audio source, you should use our RCA adapter, model MMD-FRCA.

3. Take the amplifier's power wires directly to your battery

Just go directly to the battery. Not through a 'busbar' or 'power bar'. Your AMP500.4 amplifier requires a lot of power. Go directly to the source. To the battery's terminals.

Email our support team at: support@recoilaudio.com if you have any doubts or questions.

Setup

A. Installation Applications:

The AMP500.4 is designed for operation with 12 volts, negative-ground electrical systems. Using this product in systems with positive ground and/or voltages other than 12V may result in damage to the product and will void the warranty.

B. Safety Considerations:

· Though this is a Marine IPX7 rated amplifier, mount the amplifier where it will be protected from water/mud at **all times**. Water damages are not covered by the warranty.

· While installing the amplifier, strive to find a dry and well-ventilated spot for it.



Heaving an amplifier sealed to the elements at IPX7 level means that heat generated from the amp has nowhere to escape. Playing hard with your AMP500.4 might get it Hot. **That's fine and normal.** But, avoid touching the amplifier's surface during or right after use.



Do not mount the amplifier in the engine compartment or in any areas of extreme heat. Mounting the unit in the engine compartment will void your warranty.

· Securely mount the amplifier so that it does not come loose in the event of a collision/sudden jolt or as a result of repeated vibrations during normal operation.

· Check before drilling to make sure that you will not be drilling into an exterior panel/hull, fuel tank, gas/brake line, wiring harness, or other vital system.



Do not run system wiring outside or underneath the vehicle/vessel. This is an extremely dangerous practice, which can result in severe damage/injury.

· Protect all system wires from sharp edges (metal, fiberglass, etc.) by carefully routing them, tying them down and using grommets and loom where appropriate.

· Secure all wiring as needed, using cable ties or wire clamps to protect them from moving parts and sharp edges.

C. Battery and charging:

Though your AMP500.4 control panel is already adjusted and pre-tuned, in time or for different reasons you might want to re-tune and readjust it. Take your time and make only one adjustment at a time. It may take some time to get the system fully adjusted. During this time, the amp is drawing current from the battery. You should check the battery voltage from time to time and recharge it if it gets low.



Amplifiers will put an increased load on the vehicle's battery and charging system. We recommend checking your alternator and battery condition to ensure that the electrical system has enough capacity to handle the increased load of your stereo system. Stock electrical systems which are in good condition should be able to handle the extra load of the AMP500.4 amplifier without problems, although battery and alternator life can be reduced slightly. To maximize the performance of your amplifier, we suggest the use of a heavy-duty battery and an energy storage capacitor.

Refer to section D

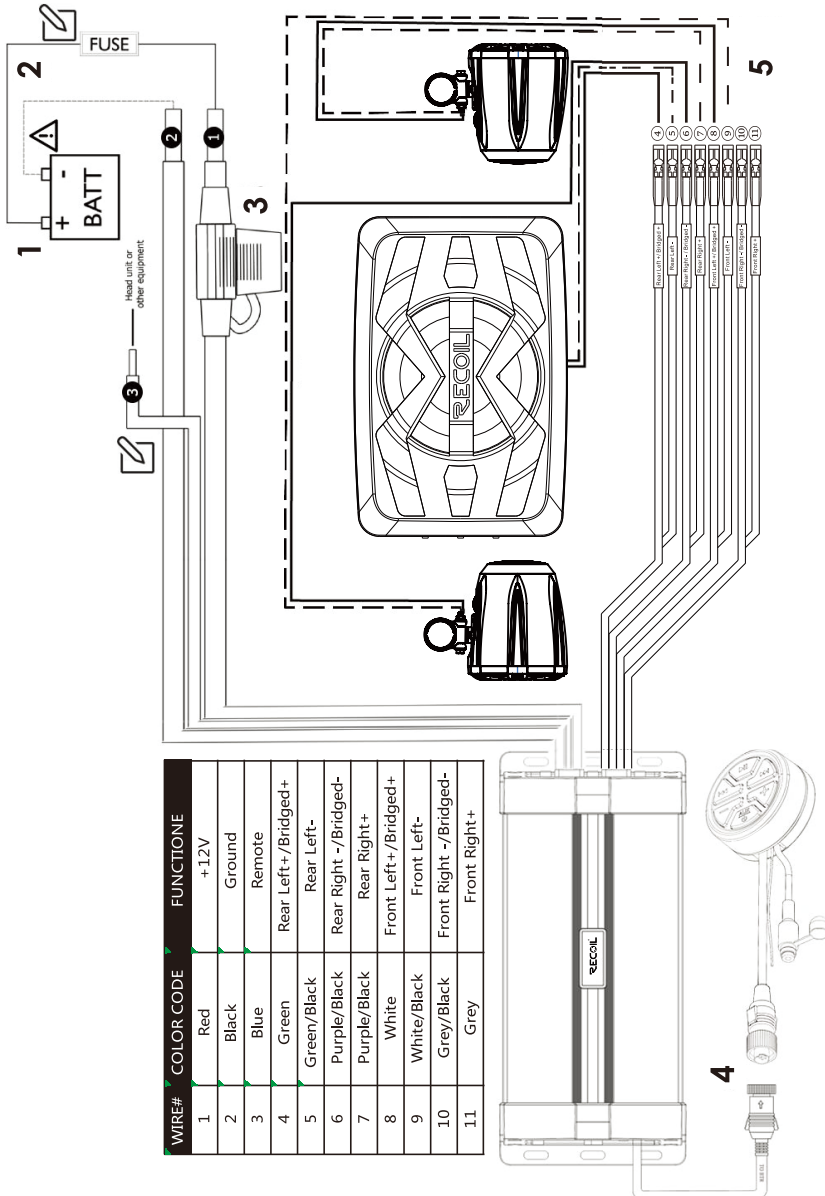

D. Installation Procedure Connections



If you feel unsure about installing this system yourself, have it installed by a qualified technician.



Before installation Disconnect the NEGATIVE battery post connection and secure the disconnected cable to prevent accidental reconnection during installation. This is an essential safety precaution during installation!



Avoid running power wires near the low-level input cables, antenna, power leads, sensitive equipment or harnesses. The power wires carry substantial current and could induce noise into the audio system.

1. Connect the RED power lead to the positive (+12V) battery post.
2. We strongly recommend to run the Black/Ground power cable to the negative (-12V) battery post.



Blue / Remote Turn-On should not be used. The RB1 controller is able to power trigger your amplifier

3. Fuse. Your AMP500.4 already includes a 40A fuse. The AMP500.4 power wires are 8' long, while the fuse housing located on the Red/Positive power wire at 5' of wire from the amplifier.



You have plenty of power wire length before the fuse holder (5'). Strive to leave no more than 18" (45.7 cm) of wire between the fuse holder and the battery positive (+12V) terminal. You can cut the remaining wire.

4. Connect the RB1 male controller DIN plug or the RCA adapter to the AMP500.4's female DIN plug.

*** Follow the arrows on the mini DIN plug of both amplifier and controller. Push the two plugs to connect only after the arrows are aligned. Plugging these plugs in the wrong direction while the arrows are not aligned can lead to bent or broken pins inside the RB1's plug.**

** Powering the AMP500.4 amplifier. Long pressing your RB1 controller's power button for few seconds will trigger both the RB1 controller and the AMP500.4 amplifier ON/OFF.

5. Run the speakers wires to the amplifier's output.
Make sure about correct polarity when connecting your speakers to the amplifier.
speakers's Red wire (+) should connect to color (+) output channels.
speakers's Black wire (-) should be connected to color / Black (-) output channels.

Speaker connection color codes:

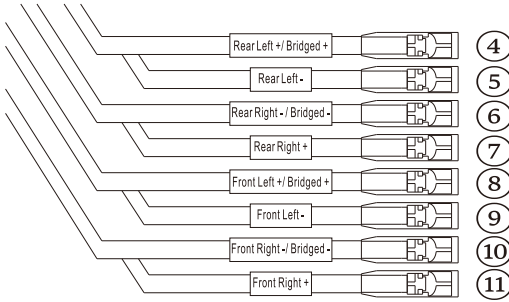

WIRE#	COLOR CODE	FUNCTIONE
1	Red	+12V
2	Black	Ground
3	Blue	Remote
4	Green	Rear Left +/ Bridged+
5	Green/Black	Rear Left-
6	Purple/Black	Rear Right -/ Bridged-
7	Purple/Black	Rear Right +
8	White	Front Left +/ Bridged+
9	White/Black	Front Left-
10	Grey/Black	Front Right -/ Bridged-
11	Grey	Front Right +

6. If you haven't already done so, mount the amp now.

7. Now you should be good to go and play tunes for the first time.

E. Control Panel Settings and Adjustments:

The amplifier's settings and controls are located on the side panel beneath a gasketed, protective cover. Remove the five Allen head screws from the center panel to access the controls and make adjustments. Replace cover when finished and mount the amplifier.

IMPORTANT! Your AMP500.4 amplifier control panel was preset to work as part of the Recoil R65 audio systems.

Your AMP500.4 amplifier's control panel was preset to fit the Recoil R65 Full-range speakers (Front channels) and Recoil WAS8 subwoofer (Rear channels) as part of the Recoil R6-P/R6-PS stereo systems. Unless you use different speakers than those supplied with your kit or in case of distortion, please avoid adjusting the gain and crossover settings of the amplifier.

This is your AMP500.4 default settings:

Front channels - White and Grey outputs. Set at full range Rear Channels - Green and Purple outputs. Set at Low-pass for a subwoofer use. If you do use a subwoofer you will want to bridge the Rear channels by using the Green/black and Purple outputs.

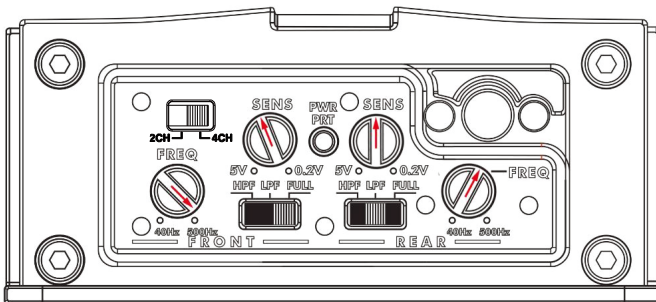

Power/Protect Indicator:

This indicator will light up RED upon initial amp start up. If all connections are OK, within 3-5 seconds the light will turn BLUE. If a condition of protect (short circuit, over/under voltage) occurs the light will turn to RED until the condition of protect is resolved.

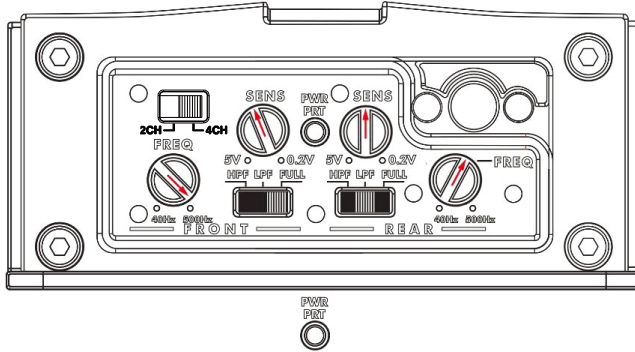

Control Panel Settings and Adjustments:

As mentioned, Your AMP500.4 amplifier's control panel was preset to fit the Recoil R65 Full-range speakers (Front channels) and Recoil WAS8 subwoofer (Rear channels) as part of the Recoil R6-P/R6-PS stereo systems. Unless you use different speakers than those supplied with your kit or in case of distortion, please avoid adjusting the gain and crossover settings of the amplifier.

AMP500.4 modes:

default settings: 2 Stereo Front + 1 Bridged Mono Rear Output

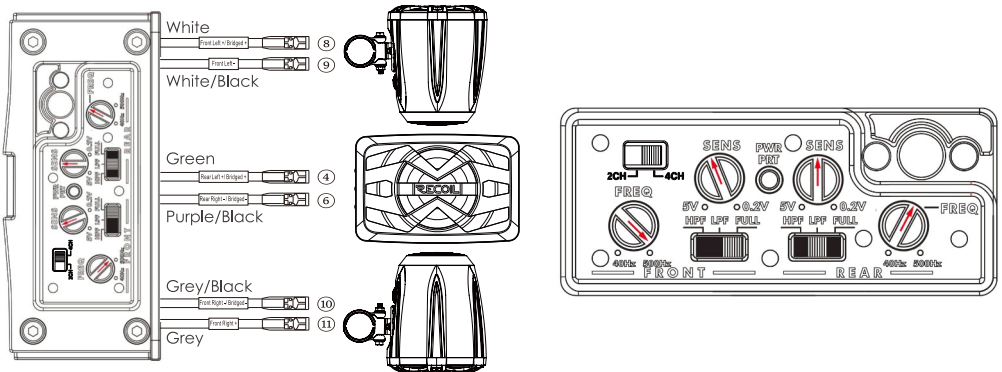

4 channels stereo mode: 2 Stereo Front + 2 Stereo Rear Output Using the amplifier with 4 full range speakers Will require you to change the settings.

* Input gain (SENS) should be tested and tuned in accordance with the used speakers and audio Source.

** Crossover control should be tuned to 'FULL'

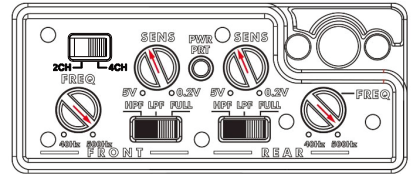
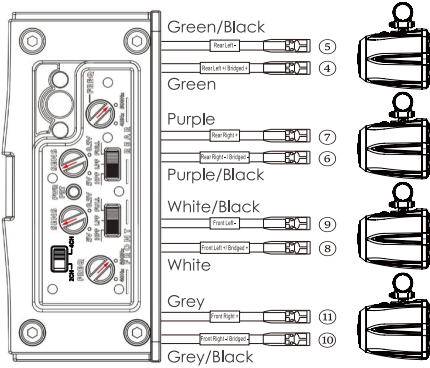

Bridge mode: 2 Bridged Outputs

The AMP500.4 can be bridged on both Front and Rear outputs to deliver 200watt RMS power off each bridged output.

* Input gain (SENS) should be tested and tuned in accordance with the used speakers and audio Source.

** DO NOT bridged the AMP500.4 to power the R65 speakers or other speakers with relatively low power handling. It might lead to a burnt voice coils and damaged speakers.

*** the drawing below shows the AMP500.4's crossover settings as both Full rang and LPF (Low-pass). This is to emphasis that it can be used either way. Set it in accordance to the speakers being used (e.g. subwoofer VS full range speaker)

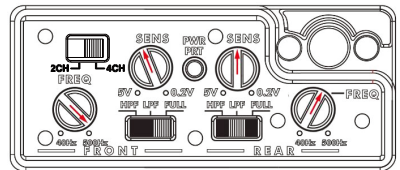
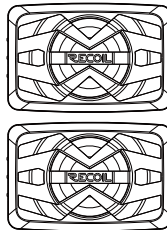
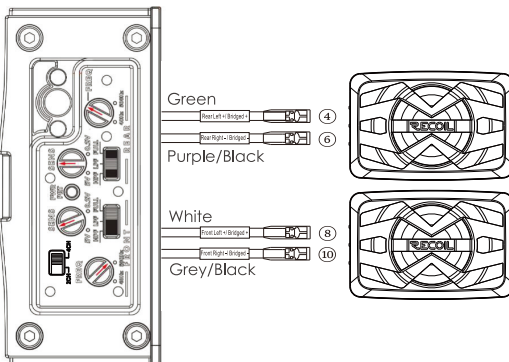

Filter mode and Sensitivity ('GAIN') settings:

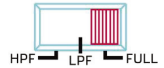

Filter mode:

HPF - (High-Pass) Configures Filter to Attenuate Frequencies BELOW the Selected Filter Frequency.

SENS - Gain settings:

This control is used to match the input of the amplifier to the source unit. The higher the sensitivity the sooner the amp will reach maximum output.

NOTE: This is NOT a volume control.

As already noted, the AMP500.4 control panel was preset to be used with the Recoil R65 and Recoil WAS8 speakers. In case you need to make adjustment to the gain settings, please follow these steps:

1. Turn the gain control (SENS) all the way down counterclockwise.
2. Turn your source/head unit, ON.
3. Set your audio source (both audio player and head unit) at full volume.
4. Slowly increase the gain control. Stop when you hear slight audio distortion.

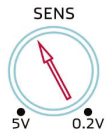

Do not increase any Input Sens. setting for any amplifier channel or channel pair in the system beyond the maximum level established during this procedure. Doing so will result in audible distortion and possible speaker damage.

Setup

Problem	Cause	Solution
It just doesn't sound right	Speaker are connected to the wrong output	Refer to section E of this owner manual
	Control panel settings are wrong	Refer to section E of this owner manual
Amplifier doesn't turn on	Controller/head unit wasn't turned ON	Did you remember to press and hold the controller's power button for 3-5 seconds?
	Faulty fuse	Remove fuse and check with continuity meter. Replace if necessary.
	Poor connection integrity	Check +12V" and Ground leads for pinched wires; ensure tight connections.
Balance Reversed	Speaker Wire L & R Reversed	Correct Speaker Wire Orientation
Output Distorted	RB1/Audio player Volume Set Too High	Lower RB1/Audio player Volume
	Amplifier Gain Set Too High	Lower Amplifier Gain (SENS)
Whining or ticking noise while the engine is ON	The amplifier is picking up alternator or radiated noise	Move the audio cables away from the power wires
		Turn Down input gain (SENS)
		Check the alternator and/ or voltage regulator. Test for weak battery or . add water to the battery



www.RecoilAudio.com

©2022, all rights reserved. Recoil and its ® logo are registered trademarks of Ningbo AVS Industrial Company, Limited. All other trademarks are property of their respective owners. AVS Industrial assumes no responsibility or liability for damages incurred with the improper use of this product.