

Installation assistance available at:
RFTECH
www.rockfordfosgate.com/rftech

P R I M E

R 1	SUBWOOFERS
-------	------------

R1S4-10 • R1S4-12



Dear Customer,

Congratulations on your purchase of the world's finest brand of car audio amplifiers. At Rockford Fosgate we are fanatics about musical reproduction at its best, and we are pleased you chose our product. Through years of engineering expertise, hand craftsmanship and critical testing procedures, we have created a wide range of products that reproduce music with all the clarity and richness you deserve.

For maximum performance we recommend you have your new Rockford Fosgate product installed by an Authorized Rockford Fosgate Dealer, as we provide specialized training through Rockford Technical Training Institute (RTTI). Please read your warranty and retain your receipt and original carton for possible future use.

Great product and competent installations are only a piece of the puzzle when it comes to your system. Make sure that your installer is using 100% authentic installation accessories from Rockford Fosgate in your installation. Rockford Fosgate has everything from RCA cables and speaker wire to power wire and battery connectors. Insist on it! After all, your new system deserves nothing but the best.

To add the finishing touch to your new Rockford Fosgate image order your Rockford accessories, which include everything from T-shirts to jackets.

Visit our web site for the latest information on all Rockford products; www.rockfordfosgate.com or, in the U.S. call 1-800-669-9899 or FAX 1-800-398-3985. For all other countries, call +001-480-967-3565 or FAX +001-480-966-3983.

Table of Content

- 2 Introduction
- 3 Specifications
- 4-5 Enclosures
 - Sealed or Vented
 - Wiring
- 6-7 Additional Languages
 - French
 - Spanish
 - German
 - Italian
- 8 Limited Warranty Information

If, after reading your manual, you still have questions regarding this product, we recommend that you see your Rockford Fosgate dealer. If you need further assistance, you can call us direct at **1-800-669-9899**. Be sure to have your serial number, model number and date of purchase available when you call.

PRACTICE SAFE SOUND

Continuous exposure to sound pressure levels over 100dB may cause permanent hearing loss. High powered auto sound systems may produce sound pressure levels well over 130dB. Use common sense and practice safe sound.

PRATIQUEZ UNE ÉCOUTE SANS RISQUES

Une exposition continue à des niveaux de pression acoustique supérieurs à 100 dB peut causer une perte d'acuité auditive permanente. Les systèmes audio de forte puissance pour auto peuvent produire des niveaux de pression acoustique bien au-delà de 130 dB. Faites preuve de bon sens et pratiquez une écoute sans risques

PRACTIQUE EL SONIDO SEGURO

El contacto continuo con niveles de presión de sonido superiores a 100 dB puede causar la pérdida permanente de la audición. Los sistemas de sonido de alta potencia para automóviles pueden producir niveles de presión de sonido superiores a los 130 dB. Aplique el sentido común y practique el sonido seguro.

PRAKTIZIEREN SIE SICHEREN SOUND

Fortgesetzte Geräuschdruckpegel von über 100 dB können beim Menschen zu permanentem Hörverlust führen. Leistungsstarke Autosoundsysteme können Geräuschdruckpegel erzeugen, die weit über 130 dB liegen. Bitte wenden Sie gesunden Menschenverstand an und praktizieren Sie sicheren Sound.

OSSERVATE LE REGOLE DEL SUONO SENZA PERICOLI

La costante esposizione a livelli di pressione acustica al di sopra dei 100dB possono causare la perdita permanente dell'udito. I sistemi audio ad alta potenza possono produrre livelli di pressione acustica ben superiori ai 130dB. Si consiglia il buon senso e l'osservanza delle regole del suono senza pericoli

Safety

This symbol with "WARNING" is intended to alert the user to the presence of important instructions. Failure to heed the instructions will result in severe injury or death.  **WARNING**

This symbol with "CAUTION" is intended to alert the user to the presence of important instructions. Failure to heed the instructions can result in injury or unit damage.  **CAUTION**

- To prevent injury and damage to the unit, please read and follow the instructions in this manual. We want you to enjoy this system, not get a headache.
- If you feel unsure about installing this system yourself, have it installed by a qualified Rockford Fosgate technician.
- Before installation, disconnect the battery negative (-) terminal to prevent damage to the unit, fire and/or possible injury.

Model	R1S4-10	R1S4-12
Nominal Impedance (Ohms)	4 Ω	4 Ω
Frequency Response (Hz)	25-250	23-250
Voice Coil Diameter - inch (mm)	2 (4-Layer) (51)	2 (4-Layer) (51)
Displacement - cu. ft. (Liter)	0.06 (1.8)	0.10 (2.8)
Fs - Free Air Resonance (Hz)	33.5	30.5
Qts	0.58	0.54
Vas - cu. ft. (Liter)	1.35 (38.1)	3.19 (90.4)
Xmax - inch (mm)	0.28 (7.0)	0.28 (7.0)
SPL (dB @ 1w/1m)	87	90
Power Handling - Watts (RMS/Peak)	200/400	200/400



CEA 2031
Power handling on Rockford Fosgate speakers conform to CEA-2031 industry standards. This means your speaker has the capacity to handle power under continuous demand, not instantaneous power handling that over time can damage voice coils.



VERIFIED WITH KLIPPEL
To adorn the 'Verified with Klippel' mark, the qualifying company's loudspeaker engineering personnel must be trained and certified by Klippel prior to using the three separate Klippel systems to design, develop and test. Rockford Fosgate has made the investment in Klippel to deliver the best possible speakers and subwoofers to their customers.

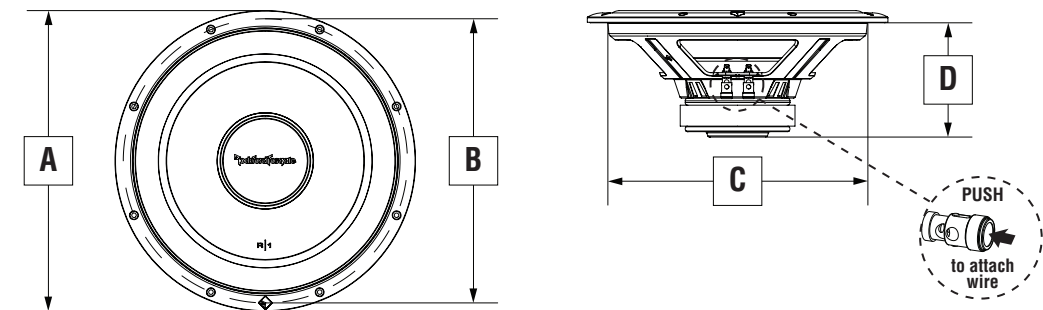

Model	R1S4-10	R1S4-12
A - Overall Diameter - inch (mm)	10.91 (277)	12.99 (330)
B- Screw Hole Dia. - inch (mm)	10.15 (257.7)	12.28 (312)
C- Mounting Dia - inch (mm)	9.05 (230)	11.22 (285)
D - Mounting Depth - inch (mm)	4.41 (112)	4.94 (125.5)

Carton Contents

- Prime R1 Subwoofer with Integrated Trim Ring
- Mounting Screws
- Operation Manual

Recommended Enclosures

This manual outlines two specific types of enclosures that provide distinctly different performance. This section is to help you decide which type is best for your application.

Sealed Enclosures

Sealed enclosures are the simplest to build. The most important part of building a sealed enclosure is to make sure that the enclosure is airtight. Using glue and some type of sealant on all seams will ensure solid construction and prevent air leaks. The box volume will directly impact the performance of the speaker. Larger enclosures will provide flatter response and deeper bass where smaller boxes will provide a bump in the response curve and generally higher output for greater SPL.

Advantages of sealed enclosures:

- Small enclosures
- Linear (Flat) response
- No port noise
- High power handling at all frequencies
- Excellent for sound quality
- Extended low frequency output when compared to vented enclosures

Vented Enclosures

Vented enclosures vary only from the sealed enclosure in that a vent or port is added to “tune” the enclosure. The enclosures recommended are designed for great overall performance. Larger boxes tend to be easy to tune to lower frequencies while medium and small boxes are easier to tune to higher frequencies. The vented design is less linear in response than the sealed box but with noticeably more output at the tuning frequency.

Advantages of vented enclosures:

- Higher average output than sealed
- Tuning frequency can be easily adjusted by changing port length
- Deep bass response with lower power requirements
- Great for high output with limited power

Vented vs Sealed

The graph shown here is a sample of how the F3 drop-off point differs between sealed and vented enclosures.

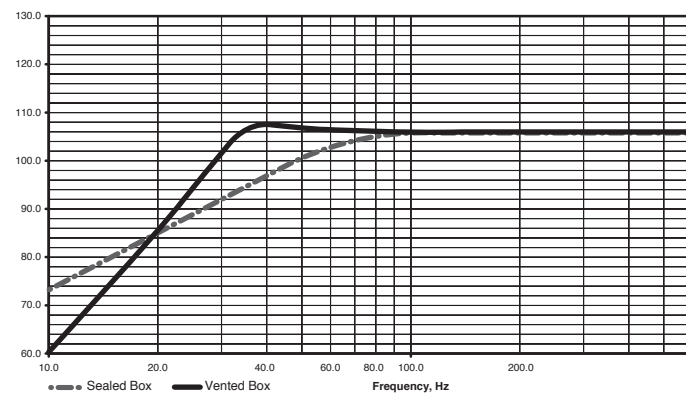

Building an Enclosure

To work properly, the walls of the enclosure must be rigid and not flex when subjected to the high pressures generated by the speaker's operation. For optimum performance, we recommend using 3/4" MDF (Medium Density Fiberboard) and internal bracing. The enclosure should be glued together and secured with nails or screws.

Calculating Volume

Calculating volume is merely a matter of measuring the dimensions in inches and using the formula: H x W x D divided by 1728 (cubic feet). See block below.

Box Volume	Height" x Width" x Depth"
Divided by (cubic feet)	1728

If two facing sides are of uneven length, add them together and divide by two to take the average. Using this number will give you the volume without the necessity of calculating the box in sections and adding the sections together. The thickness of the baffle material reduces the internal volume so this must be subtracted from the outside dimensions to determine the internal volume. The speaker itself also reduces the internal volume. The amount of air displaced by each model is listed on the specification sheet and should also be subtracted from the gross volume calculation.

Sealed Enclosures

NOTE: V_b is the gross volume, which is the TOTAL internal volume, before any speaker and/or port displacement. All external dimensions were based on the use of 3/4" (1.90 cm) materials.

NOTE: When using enclosures other than recommended, call Technical Support for correct application.

Optimum Sealed Enclosure Recommendation

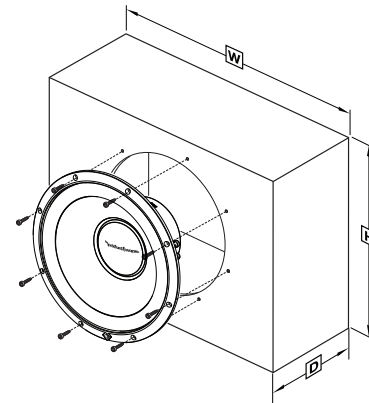

Sealed Enclosures	R1S4-10	R1S4-12
V _b - Internal Area cu. ft. (Liter)	0.59 (16.71)	1.02 (28.88)
F ₃ - 3dB Point (Hz)	48	43
Q _{tc} - Enclosure Damping	0.83	0.87
H - Height - inch (cm)	12.0 (30.48)	14.0 (35.56)
W - Weight - inch (cm)	14.0 (35.56)	18.0 (45.72)
D - Depth - inch (cm)	9.25 (23.50)	10.0 (25.40)

Recommended Sealed Enclosure Volum Range

Sealed Enclosures	R1S4-10	R1S4-12
V _b - Volume range cu. ft. (Liter)	0.50 to 0.85 (14.16 to 24.07)	0.7 to 1.8 (19.82 to 50.97)

Vented Enclosures

NOTE: V_b is the gross volume, which is the TOTAL internal volume, before any speaker and/or port displacement. All external dimensions were based on the use of 3/4" (1.90cm) materials.

NOTE: When using enclosures other than recommended, call Technical Support for correct application.

Optimum Vented (Ported) Enclosure Sizes

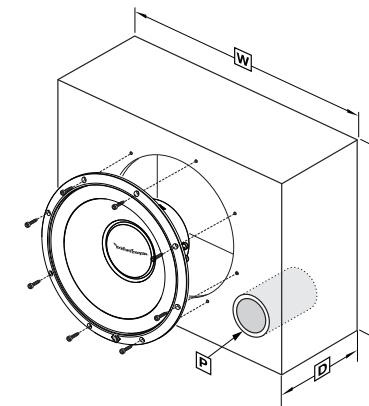

Vented Enclosures	R1S4-10	R1S4-12
V _b - Internal Area cu. ft. (Liter)	1.4 (39.64)	1.79 (50.69)
F _B - Tuning Frequency (Hz)	37.3	36.3
F ₃ - 3dB Point (Hz)	32.0	32.5
H - Height - inch (cm)	12.0 (30.48)	14.0 (35.56)
W - Weight - inch (cm)	20.0 (50.80)	25.0 (63.50)
D - Depth - inch (cm)	14.0 (35.56)	12.0 (30.48)
P - Port Diameter and Length - inch (cm)	(1) 3 x 8 (1) (7.62x20.32)	(1) 3 x 6 (1) (7.62x15.24)

Wiring Configurations

By varying the wiring configuration of your speakers you can create an impedance load to match your system. Altering the wiring configurations gives a range of options for impedance loads. Series, Parallel, or Series-Parallel wiring configurations are different techniques for wiring speakers that provide different loads. Series configuration is a string method where speakers are wired end to end. Parallel configuration uses two or more speakers wired across common terminals. Series-Parallel configuration combines both techniques. Choose the wiring diagram that corresponds to the number of woofers and the impedance of your amplifier.

Subwoofer Crossovers

There are two operational types of crossovers, passive and active. Passive crossovers (coils or inductors) are placed on the speaker leads between the amplifier and speaker. An active crossover is an electronic filter that separates the audio signal fed to different amplifiers. For optimum subwoofer performance, we recommend using an active 80-100Hz low-pass crossover at 12dB/octave.

Parallel Wiring

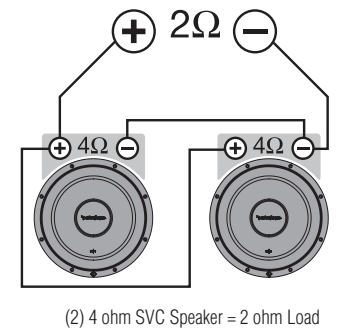

Series/Parallel Wiring

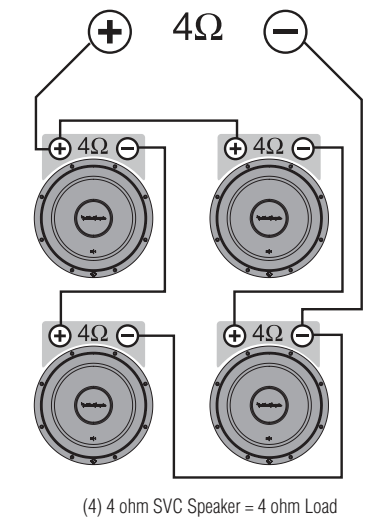

Rockford Corporation offers a limited warranty on Rockford Fosgate products on the following terms:

Length of Warranty

Speakers, Signal Processors, PRIME and PUNCH Amplifiers – 1 Year
POWER Amplifiers – 2 Years
Any Factory Refurbished Product – 90 days (receipt required)

What is Covered

This warranty applies only to Rockford Fosgate products sold to consumers by Authorized Rockford Fosgate Dealers in the United States of America or its possessions. Product purchased by consumers from an Authorized Rockford Fosgate Dealer in another country are covered only by that country's Distributor and not by Rockford Corporation.

Who is Covered

This warranty covers only the original purchaser of Rockford product purchased from an Authorized Rockford Fosgate Dealer in the United States. In order to receive service, the purchaser must provide Rockford with a copy of the receipt stating the customer name, dealer name, product purchased and date of purchase.

Products found to be defective during the warranty period will be repaired or replaced (with a product deemed to be equivalent) at Rockford's discretion.

What is Not Covered

1. Damage caused by accident, abuse, improper operations, water, theft, shipping.
2. Any cost or expense related to the removal or reinstallation of product.
3. Service performed by anyone other than Rockford or an Authorized Rockford Fosgate Service Center.
4. Any product which has had the serial number defaced, altered, or removed.
5. Subsequent damage to other components.
6. Any product purchased outside the U.S.
7. Any product not purchased from an Authorized Rockford Fosgate Dealer.

Limit on Implied Warranties

Any implied warranties including warranties of fitness for use and merchantability are limited in duration to the period of the express warranty set forth above. Some states do not allow limitations on the length of an implied warranty, so this limitation may not apply. No person is authorized to assume for Rockford Fosgate any other liability in connection with the sale of the product.

How to Obtain Service

Contact the Authorized Rockford Fosgate Dealer you purchased this product from. If you need further assistance, call 1-800-669-9899 for Rockford Customer Service. You must obtain an RA# (Return Authorization number) to return any product to Rockford Fosgate. You are responsible for shipment of product to Rockford.

EU Warranty

This product meets the current EU warranty requirements, see your Authorized dealer for details.